

2023

Gdynia Sailing Days

**Polish RS21 Cup
8-9 July 2023**

SAILING INSTRUCTIONS



**POLSKI
ZWIĄZEK
ŻEGLARSKI**

**Polish RS21 Cup
Act 3, Gdynia
08-09 July 2023
Sailing Instruction (SI)**

1. RULES

- 1.1. The event shall be governed by the Rules as defined in the Notice of Race (NoR).
- 1.2. If there is a conflict between the NoR and the SI the SI takes precedence.

2. NOTICES TO COMPETITORS

- 2.1. Notices to competitors will be posted on the Online Notice Board (ONB) https://events.pya.org.pl/rs-cup_e107.
- 2.2. The OA, the RC and the Jury will use a WhatsApp group to communicate unofficially with competitors. This does not replace the ONB.

3. CHANGES TO SAILING INSTRUCTIONS

- 3.1. Any changes to the Sailing Instructions will be posted at least 1 hour before the first start of the day, with the exception of changes to the race program which will be posted by 20:00 hours on the day before they take effect.
- 3.2. In accordance with RRS rule 90.2(c) oral changes to the SI's may be made on the water and transmitted via VHF CH72.

4. SIGNALS MADE ASHORE

- 4.1. Signals made ashore will be displayed on the official flagpole located in Yacht Klub Polski Gdynia.
- 4.2. When flag AP is displayed ashore, "1 minute" is replaced with "not less than 30 minutes".
- 4.3. Flag AP over H displayed ashore means: "Races not started are postponed; Vessels shall not leave the harbour" [This changes RRS Race Signals].

5. SCHEDULE OF RACES

- 5.1. 11 races are planned.
- 5.2. Daily schedule:
 - 5.2.1. Saturday, July 8th – warning signal 11:00
 - 5.2.2. Sunday, July 9th – warning signal 10:00

6. CLASS FLAG

The Class flag will be the RS Sailing Class flag.

7. RACING AREA

- 7.1. Addendum 1 shows the location of racing areas.
- 7.2. Classes assigned to racing areas will be posted on ONB.
- 7.3. Racing areas will be marked as follows:

Organizator:



POLSKI
ZWIĄZEK
ŻEGLARSKI

Współorganizator:



SAMORZĄD
WOJEWÓDZTWA POMORSKIEGO

Partner Główny:



Ministerstwo
Sportu i Turystyki

Partner Strategiczny:



Patronat Honorowy:



MIECZYŚLAW STRUK
MARSZAŁEK
WOJEWÓDZTWA POMORSKIEGO

Partner



Partner



Racing area	Insignia
ALPHA	White flag with black letters ALPHA
BRAVO	Red flag with black letters BRAVO
CHARLIE	Green flag with black letters CHARLIE
DELTA	Yellow flag with black letters DELTA

8. COURSE

8.1. Course shall be windward/leeward with a leeward gate, finishing downwind according to diagram.

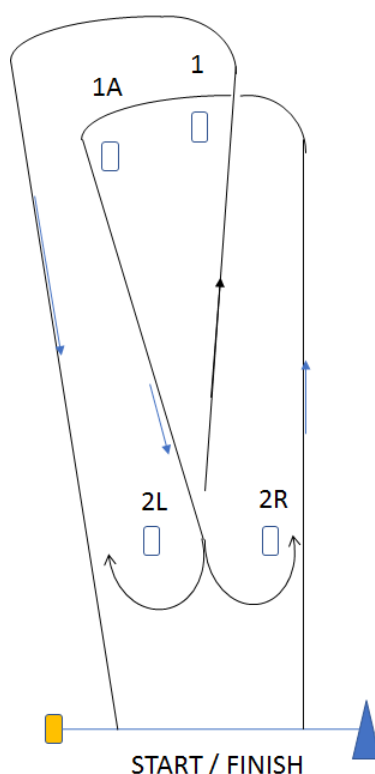

8.2. The course is 2 laps with possibility of shortening.

8.3. If a gate is replaced by a single mark, it shall be rounded to port.

9. MARKS

9.1. Marks 1, 1A, 2S, 2P will be white buoys.

9.2. Starting marks will be the RC vessel displaying the orange flag on the starboard side and an orange marks on the port side.

9.3. Finishing mark will be the RC vessel displaying blue flag on the port side and an orange buoy on the starboard side.

Organizator:



POLSKI
ZWIĄZEK
ŻEGLARSKI

Współorganizator:



SAMORZĄD
WOJEWÓDZTWA POMORSKIEGO

Partner Główny:



Ministerstwo
Sportu i Turystyki

Partner Strategiczny:



Patronat Honorowy:



MIECZYŚLAW STRUK
MARSZAŁEK
WOJEWÓDZTWA POMORSKIEGO

Partner



Partner



10. PROHIBITED AREAS

Prohibited areas will be marked by small yellow and orange marks. Boats entering the prohibited area will be penalised by the Jury.

11. THE START

11.1. The RC will NOT communicate individual recalls via VHF radio.

11.2. A boat that does not start within 4 minutes of after the starting signal will be scored DNS without a hearing. [This changes RRS A4 and A5].

12. CHANGE OF THE NEXT LEG OF THE COURSE

In the event of a course change, the race committee will move the original mark to its new position.

13. PENALTY SYSTEM AND ARBITRATION

The penalty system will be detailed in Appendix UF – RS21 Edition. RRS Appendix T may be used.

14. TIME LIMIT AND TARGET TIMES

14.1. A race target time will be 30 minutes.

14.2. Time limit for mark 1 will be 15 minutes.

14.3. Time limit will be 60 minutes.

14.4. Boats that fail to finish the race within 5 minutes after first boat in the race has finished, will be scored TLE (Time Limit Expired) without a hearing and scored one point more than the number of boats that finished. [This changes rules 35, A4, A5 and A10].

14.5. If no boat has completed the first leg within 20 minutes after the starting signal, the race will be abandoned. Failure to meet the target time will not be grounds for redress. [This amends RRS 62.1(a)].

15. SCORING

A boat's series score when:

15.1. fewer than 4 races have been completed will be the total of her race scores

15.2. when from 4 to 8 races have been completed will be total of her race scores excluding her worst score

15.3. when 9 or more races have been completed will be total of her race scores excluding her two worst scores

16. PROTESTS AND REQUEST FOR REDRESS

16.1. For the purpose of RRS 64.34 (b) the authority is the chief measurer of the event, appointed by the organizing authority.

16.2. RRS Appendix UF - RS21 Edition applies.

Organizator:



POLSKI
ZWIĄZEK
ŻEGLARSKI

Współorganizator:



SAMORZĄD
WOJEWÓDZTWA POMORSKIEGO

Partner Główny:



Ministerstwo
Sportu i Turystyki

Partner Strategiczny:



Patronat Honorowy:



MIECZYŚLAW STRUK
MARSZAŁEK
WOJEWÓDZTWA POMORSKIEGO

Partnerzy:



Partnerzy:



17. SAFETY REGULATIONS [NP] [DP]

A boat that retires from a race shall inform, by any means, the RC. Breaches of this SI may be subject to further action by the Jury.

18. REPLACEMENT OF CREW OR EQUIPMENT [NP] [DP]

- 18.1. Replacement of crew will not be allowed without prior approval of the Race Committee.
- 18.2. Replacement of damaged or lost equipment will not be allowed unless approved by the Technical Committee.

19. EQUIPMENT AND MEASUREMENT CHECKS

A boat or its equipment may be inspected at any time for compliance with the Class Rules and Sailing Instructions. On the water, a boat can be instructed by the Technical Committee or Race Committee to proceed immediately to a designated area for inspection.

20. EVENT ADVERTISING [DP] [NP]

Boats shall display event advertising stickers supplied by Organizing Authority.

21. RADIO COMMUNICATION

- 21.1. The official radio channel will be VHF channel announced at skippers briefing
- 21.2. From the first warning signal until the end of the last race of that day, except in an emergency or to communicate with the race committee or umpires, a boat shall not make voice or data transmissions and shall not receive voice or data communications not available to all boats. This restriction also applies to cell phones and any other similar devices.

22. PRIZES

Top three crews will be awarded trophies.

23. DISCLAIMER OF LIABILITY

Competitors participate in the regatta entirely at their own risk. See RRS rule 3, Decision to Race. The Organizing Authority, the Racing Committee and the Protest Committee will not accept any liability for material damage or personal injury or death occurring in conjunction with or prior to, during, or after the regatta.

24. INSURANCE

Each boat shall be insured with a valid third-party liability insurance with a minimum coverage of € 1.500.000, 00, or the equivalent if expressed in a different currency. The insurance must include the extension for the race. Proof of valid insurance certificate shall be provided upon registration.

Organizator:



POLSKI
ZWIĄZEK
ŻEGLARSKI

Współorganizator:



SAMORZĄD
WOJEWÓDZTWA POMORSKIEGO

Partner Główny:



Ministerstwo
Sportu i Turystyki

Partner Strategiczny:



Patronat Honorowy:



MIECZYŚLAW STRUK
MARSZAŁEK
WOJEWÓDZTWA POMORSKIEGO

Partnerzy



Partnerzy



ADDENDUM 1 – RACING AREAS

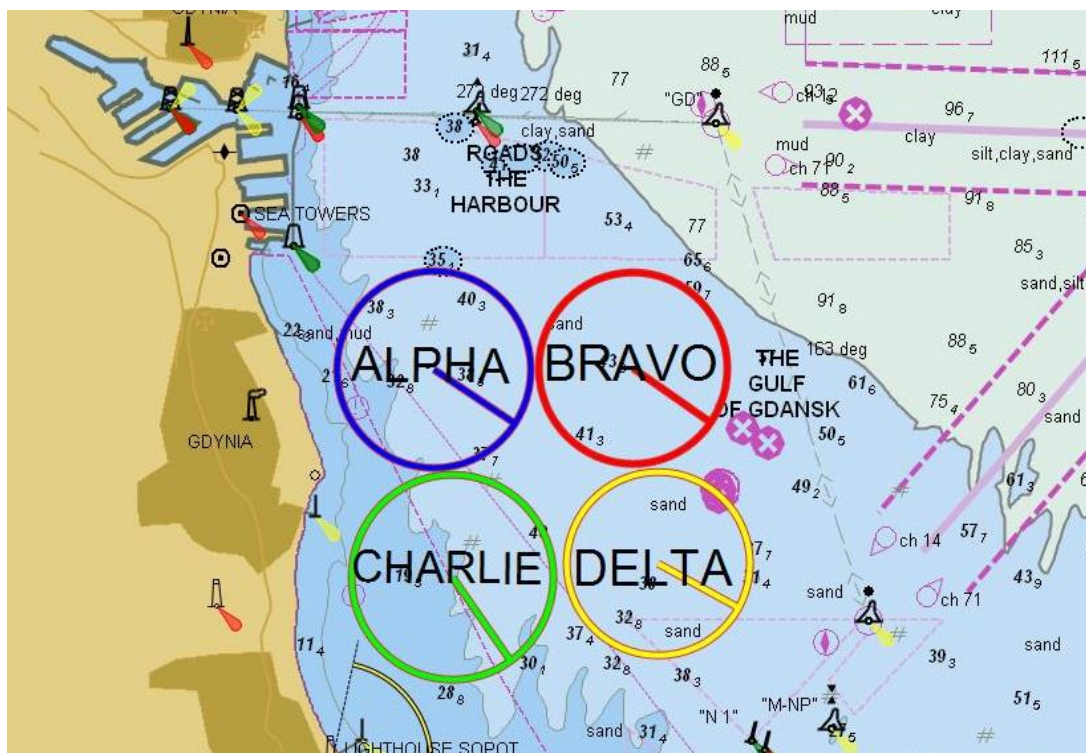

Organizator:



POLSKI ZWIĄZEK ŻEGLARSKI

Współorganizator:



SAMORZĄD WOJEWÓDZTWA POMORSKIEGO

Partner Główny:



Ministerstwo Sportu i Turystyki

Partner Strategiczny:



Patronat Honorowy:



MIECZYSLAW STRUK
MARSZAŁEK
WOJEWÓDZTWA POMORSKIEGO

Partnerzy



Partnerzy



APPENDIX UF

UMPIRED FLEET RACING

Version: October 18th 2022

Umpired fleet races shall be sailed under The Racing Rules of Sailing as changed by this appendix. Races shall be umpired. The rule changes in UF1 have been approved by World Sailing under Regulation 28.1.5(b) on the condition that only the provided options are used. This appendix applies only when it is referred to in the Notice of Race and made available for all competitors.

UF 1 CHANGES TO THE DEFINITIONS, THE RULES OF PART 1 AND 2, AND RULE 70

UF 1.1 Add to the definition Proper Course: 'A boat taking a penalty or manoeuvring to take a penalty is not sailing a proper course.'

UF 1.2 ADD NEW RULE 7 TO PART 1:

LAST POINT OF CERTAINTY

The umpires will assume that the state of a boat, or her relationship to another boat, has not changed, until they are certain that it has changed.'

UF1.4 When rule 20 applies, the following arm signals are required in addition to the hails:

(a) for room to tack, repeatedly and clearly pointing to windward; and

(b) for 'You tack', repeatedly and clearly pointing at the other boat and waving the arm to windward.

UF1.5 Rule 70 is deleted.

UF2 CHANGES TO OTHER RULES

Spare

UF3 ON WATER PROTESTS AND PENALTIES

UF3.1 In this appendix, 'a penalty' will mean the following:

Organizator:



Współorganizator:



Partner Główny:



Partner Strategiczny:



Patronat Honorowy:



A One-Turn Penalty taken in accordance with rule 44.2. However, when a boat may have broken a rule of part 2 while in the zone of a starting mark, rounding mark, finishing mark or rule 20, her Penalty shall be a Two-Turn Penalty taken in accordance with rule 44.2 Penalties may not be taken inside the zone of a starting mark, rounding mark, or while on a windward spreader leg.

UF3.2 The first sentence of rule 44.1 is changed to: 'A boat may take a penalty when, in an incident while racing, she may have broken one or more of the rules of Part 2 (except rule 14 when she has caused damage or injury), rule 31, rule 42, or class rules C10.1 and C3.3. However, when she may have broken a rule of Part 2 and rule 31 in the same incident, she need not take the penalty for breaking rule 31'.

UF3.3 On the Water Protests by Boats and Penalties

(a) While racing, a boat may protest another boat under a rule of Part 2 (except rule 14) or under rule 31 or rule 42; however, a boat may only protest under a rule of Part 2 for an incident in which she was involved. To do so she shall hail 'Protest' and conspicuously display a red flag at the first reasonable opportunity for each. She shall remove the flag before, or at the first reasonable opportunity after a boat involved in the incident has taken a penalty voluntarily or after an umpire's decision.

(b) A boat that protests as provided in rule UF3.3(a) is not entitled to a hearing, unless an umpire signals in accordance with UF3.5(d), or no umpire signal is made at all. Instead, a boat involved in the incident may acknowledge breaking a rule by voluntarily taking a penalty. An umpire may penalize any boat that broke a rule and was not exonerated, unless the boat took a penalty voluntarily.

UF3.4 Penalties and Protests Initiated by an Umpire

(a) When a boat

(1) breaks rule 31 and does not take a penalty,

(2) breaks rule 42,

(3) gains an advantage despite taking a penalty,

(4) commits a breach of sportsmanship, or

(5) fails to comply with rule UF3.6 or to take a penalty when required to do so by an umpire,

Organizator:



POLSKI
ZWIĄZEK
ŻEGLARSKI

Współorganizator:



SAMORZĄD
WOJEWÓDZTWA POMORSKIEGO

Partner Główny:



Ministerstwo
Sportu i Turystyki

Partner Strategiczny:



Patronat Honorowy:



MIECZYŚLAW STRUK
MARSZAŁEK
WOJEWÓDZTWA POMORSKIEGO

Partner



Partner



(6) breaks class rules C3.3 (crew positioning), or C10.1 (bowsprit), an umpire may penalize her without a protest by another boat. The umpire may impose a penalty or more, each signaled in accordance with rule UF 3.5(b), or disqualify her under rule UF3.5(c), or report the incident to the protest committee for further action. If a boat is penalized under rule UF 3.4: (a) (5) for not taking a penalty or taking a penalty incorrectly, the original penalty is cancelled, (b) An umpire who decides, based on his own observation or a report received from any source, that a boat may have broken a rule, other than rule UF3.6 or a rule listed in rule UF 3.3(a), may inform the protest committee for its action under rule 60.3. However, he will not inform the protest committee of an alleged breach of rule 14 unless there is damage or injury.

UF3.5 Umpire Signals

An umpire will signal a decision as follows:

- (a) A green and white flag with one long sound means 'No penalty.'
- (b) A red flag with one long sound means 'a penalty is imposed or remains outstanding.' The umpire will hail or signal to identify each such boat.
- (c) A black flag with one long sound means 'A boat is disqualified.' The umpire will hail or signal to identify the boat disqualified.
- (d) A blue flag with one long sound means 'The umpires do not have the facts required to make a decision.'

UF3.6 Imposed Penalties

- (a) A boat penalized under rule UF3.5(b) shall take a penalty.
- (b) A boat disqualified under rule UF3.5(c) shall promptly leave the course area.

UF4 RACE COMMITTEE ACTIONS

UF4.1 After boats have finished, the race committee will inform competitors about the results on the official noticeboard. After this has been done, the race committee will promptly display flag B with one sound. Flag B will be displayed for at least two minutes and then removed with one sound. If the race committee changes the scoring information provided at the finishing line while flag B is displayed, it will display flag L with one sound. Flag B will continue to be displayed for at least two minutes after any changes are made.

Organizator:



POLSKI
ZWIĄZEK
ŻEGLARSKI

Współorganizator:



SAMORZĄD
WOJEWÓDZTWA POMORSKIEGO

Partner Główny:



Ministerstwo
Sportu i Turystyki

Partner Strategiczny:



Patronat Honorowy:



MIECZYŚLAW STRUK
MARSZAŁEK
WOJEWÓDZTWA POMORSKIEGO

Partner



UF5 PROTESTS; REQUESTS FOR REDRESS OR REOPENING; APPEALS

UF5.1 No proceedings of any kind may be taken in relation to any action or non-action by an umpire.

UF5.2 A boat is only entitled to a hearing when:
the umpires have signaled in accordance with UF3.5(d),
when no umpire signal was made and no boat involved in the incident has taken a penalty voluntarily
or under UF5.3.

UF5.3 A boat intending to
(a) protest another boat under a rule other than rule UF3.6, or a rule listed in rule UF3.3(a),
(b) protest another boat under rule 14 if there was contact that caused damage or injury, or (c) request redress shall inform the race committee in the following way: by hailing the race committee on VHF Radio before or during the display of flag B

UF5.4 The time limit defined in rule UF5.3 also applies to protests under rule UF5.9, UF5.10 and UF5.11 when such protests are permitted. The protest committee shall extend the time limit if there is good reason to do so.

UF5.5 The race committee will promptly inform the protest committee about any protests or requests for redress made under rule UF5.3.

UF5.6 The third sentence of rule 61.1(a) and all of rule 61.1(a) (2) are deleted.

UF5.7 The first three sentences of rule 64.2 are changed to: 'When the protest committee decides that a boat that is a party to a protest hearing has broken a rule, it may impose penalties other than disqualification, and may make any other scoring arrangement it decides is equitable. If a boat has broken a rule when not racing, the protest committee shall decide whether to apply any penalty to the race sailed nearest in time to that of the incident or make some other arrangement.'

UF5.8 Hearings
Except for a hearing under rule 69.2

Organizator:



POLSKI
ZWIĄZEK
ŻEGLARSKI

Współorganizator:



SAMORZĄD
WOJEWÓDZTWA POMORSKIEGO

Partner Główny:



Ministerstwo
Sportu i Turystyki

Partner Strategiczny:



Patronat Honorowy:



MIECZYŚLAW STRUK
MARSZAŁEK
WOJEWÓDZTWA POMORSKIEGO

Partner



Partner



(a) Protests and requests for redress need not be in writing.

(b) The protest committee may inform the protestee and schedule the hearing in any way it considers appropriate and may communicate this orally.

(c) The protest committee may take evidence and conduct the hearing in any way it considers appropriate and may communicate its decision orally.

(d) If the protest committee decides that a breach of a rule has had no effect on the outcome of the race, it may impose a scoring penalty of points or fraction of points or make any other arrangement it decides is fair, which may be to impose no penalty.

(e) If the protest committee penalizes a boat in accordance with rule UF5.7 or if a standard penalty is applied, all other boats will be informed about the change of the penalized boat's score.

UF5.9 The race committee will not protest a boat except for rule 31.

UF5.10 The protest committee may protest a boat under rule 60.3. However, it will not protest a boat for breaking rule UF3.6, a rule listed in rule UF 3.3(a), or rule 14 unless there is damage or injury.

UF5.11 The technical committee will only protest a boat under rule 60.4 when it decides that a boat or personal equipment does not comply with the class rules, rule 50, or the rules in the equipment regulations of the event, if such exist. In such a case, the technical committee shall protest.

UF5.12 Rule 66.2 is changed to 'A party to the hearing under this appendix may not request a reopening.'

Organizator:



POLSKI
ZWIĄZEK
ŻEGLARSKI

Współorganizator:



SAMORZĄD
WOJEWÓDZTWA POMORSKIEGO

Partner Główny:



Ministerstwo
Sportu i Turystyki

Partner Strategiczny:



Patronat Honorowy:



MIECZYŚLAW STRUK
MARSZAŁEK
WOJEWÓDZTWA POMORSKIEGO

Partner



Partner

